

RollEase®



Architectural Custom Collection



Oxford
House

800-533-9464

Sales@oxford-house.com

RollEase®

Product Features and Options

The performance and reliability of the RollEase Roller Shade system far exceeds that of a spring roller, look-alike clutch or a friction brake mechanism. Once you compare our superior quality, outstanding performance and ease of use you'll see why our patented mechanism is the system preferred by a wide majority of architects, interior decorators and building tenants.

Features:

An adjustment free, patented clutch technology controlled by a stainless-steel ball chain or plastic beaded chain. The clutch is comprised of multi-banded steel springs that lock the shade in the desired precise position. When the bead chain is pulled, the clutch completely releases allowing the shade to be freely raised or lowered.

Multiple clutch sizes for operational flexibility and cost efficiency. Five clutch capacity sizes: 8, 16, 24, 30, and 53 lbs.

Clutch made from durable glass reinforced polyester thermopolymer (PBT) for wear resistance, smooth operation, and corrosion resistance.

Widest variety of clutch options featuring award winning and patented technology advancements which provide the smoothest and easiest pull forces in the industry.

Multiple tube sizes and clutch housings available: 1, 1 1/8, 1 1/4, 1 1/2, 2, and 2 1/2 inch

Universal brackets, in 16-gauge enameled galvanized steel, capable of being mounted in any position.

Edge clearance from the shade band to the inside of the jamb: 3/8" and 5/8" at the clutch end.

Options:

A fascia system made from extruded-aluminum that snap onto the mounting brackets. No exposed hardware. Available in Black, Bronze and White.

Multiple sized aluminum pockets with bottom-closures and black-out side and bottom channels.

Why RollEase Clutches?

- All clutches are based on RollEase's proven multi-spring design
- Manufactured to tolerances within 2/1000 of an inch (1/20mm), RollEase clutches never need adjusting
- All clutch components other than springs are made of a glass reinforced thermopolymer to ensure years of trouble free performance and prevent oxidation of external materials

Technology inside the R-series clutch

RollEase pioneered the roller shade clutch and has perfected the manufacturing process of operating systems since their introduction in the 1980's. RollEase has more than 25 patents for invention with a full time staff of design engineers working exclusively on improvements and extensions of existing systems as well as the development of new operating systems.

HOW IT WORKS

A clutch utilizes a wrap spring which can either be tightened or loosened on an inner core. Push on one side of the spring tang and the spring diameter decreases, locking any movement. Push the tang on the other side and the spring opens, allowing free shade movement.

The clutch is divided into two separate interior, interlocking cores, the first of which is on the outside (shade tube housing) where the roller shade tube is attached (fabric is rolled onto the tube). The inner core is attached to the bead chain pulley. Both cores have cams which are arranged to push on a particular side of the spring tang.

- The pulley core has a cam which is positioned below the spring tangs. When the pulley is moved in either direction (by pulling on the bead chain) it pushes against the spring tang opening the springs diameter and allowing free shade movement.
- Release the bead chain and the spring automatically returns to its original, closed shape, locking the shade in position.
- The shade tube housing has a cam positioned so that the force of the hanging shade pushes on the side of the spring tang locking it tightly to the inner core. The weight of the shade helps keep the shade locked. The more weight on the shade, the tighter the spring locks.

RollEase multi-spring configuration distributes the interior forces evenly over the inner core and offers the industry's smoothest pull. The ratio between the bead chain pulley and the shade tube provides a mechanical advantage allowing the pull forces to raise a shade to be less than the actual weight of the shade.

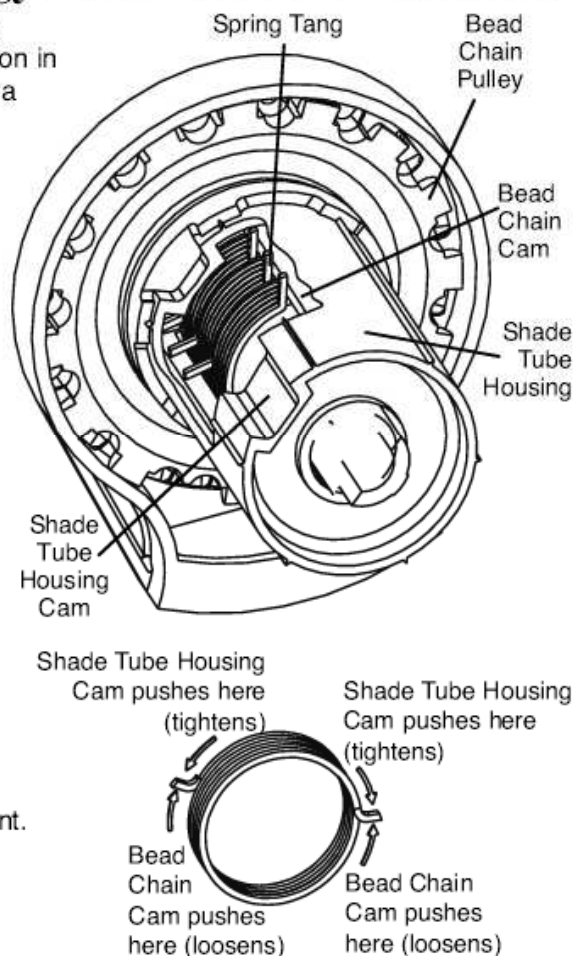

Overview of R-Series

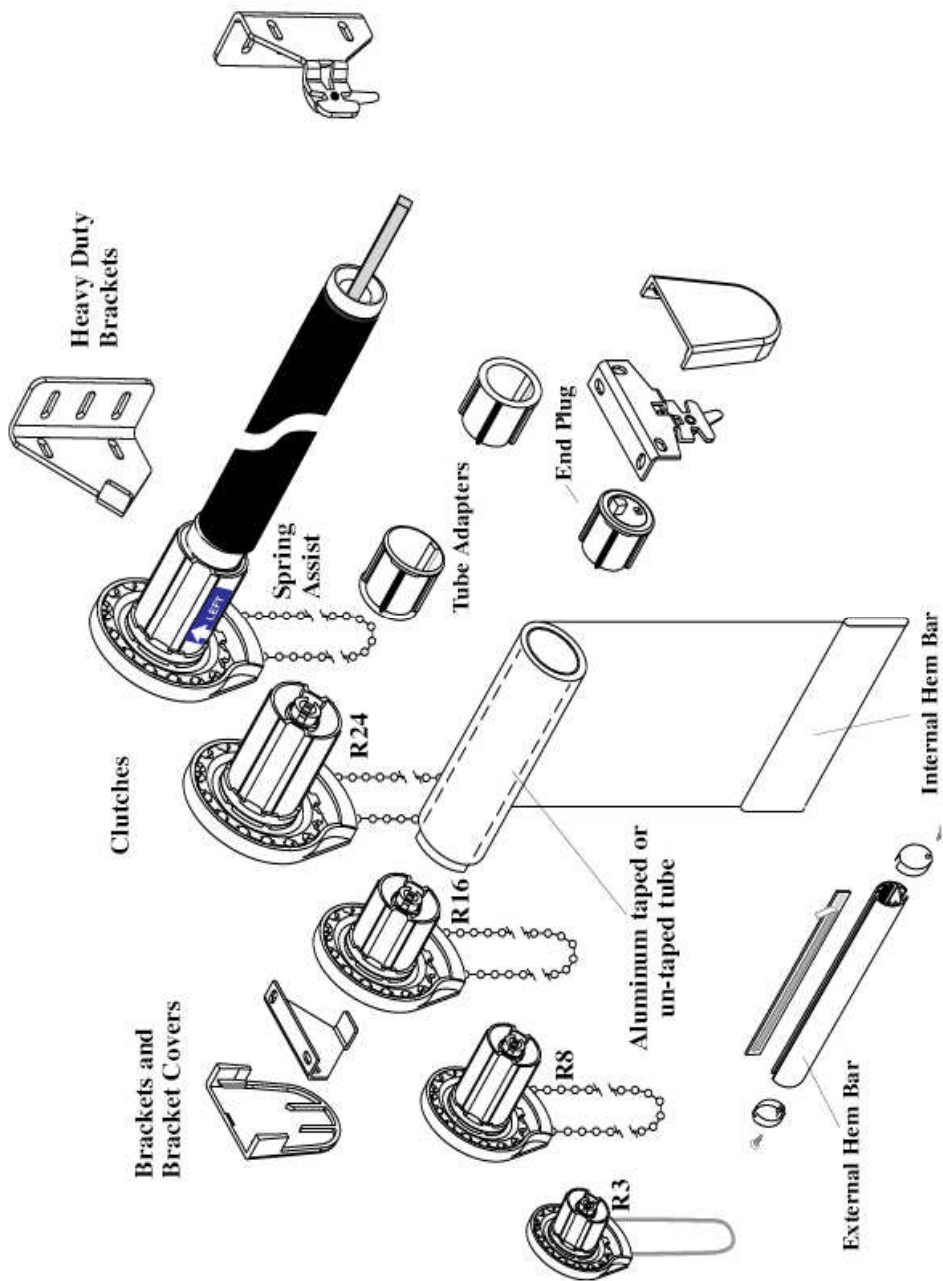

See Motorization tab for overview of how easily it is retrofit from manual to motorized operation



Cassette Headrails, Fascia and Raceway

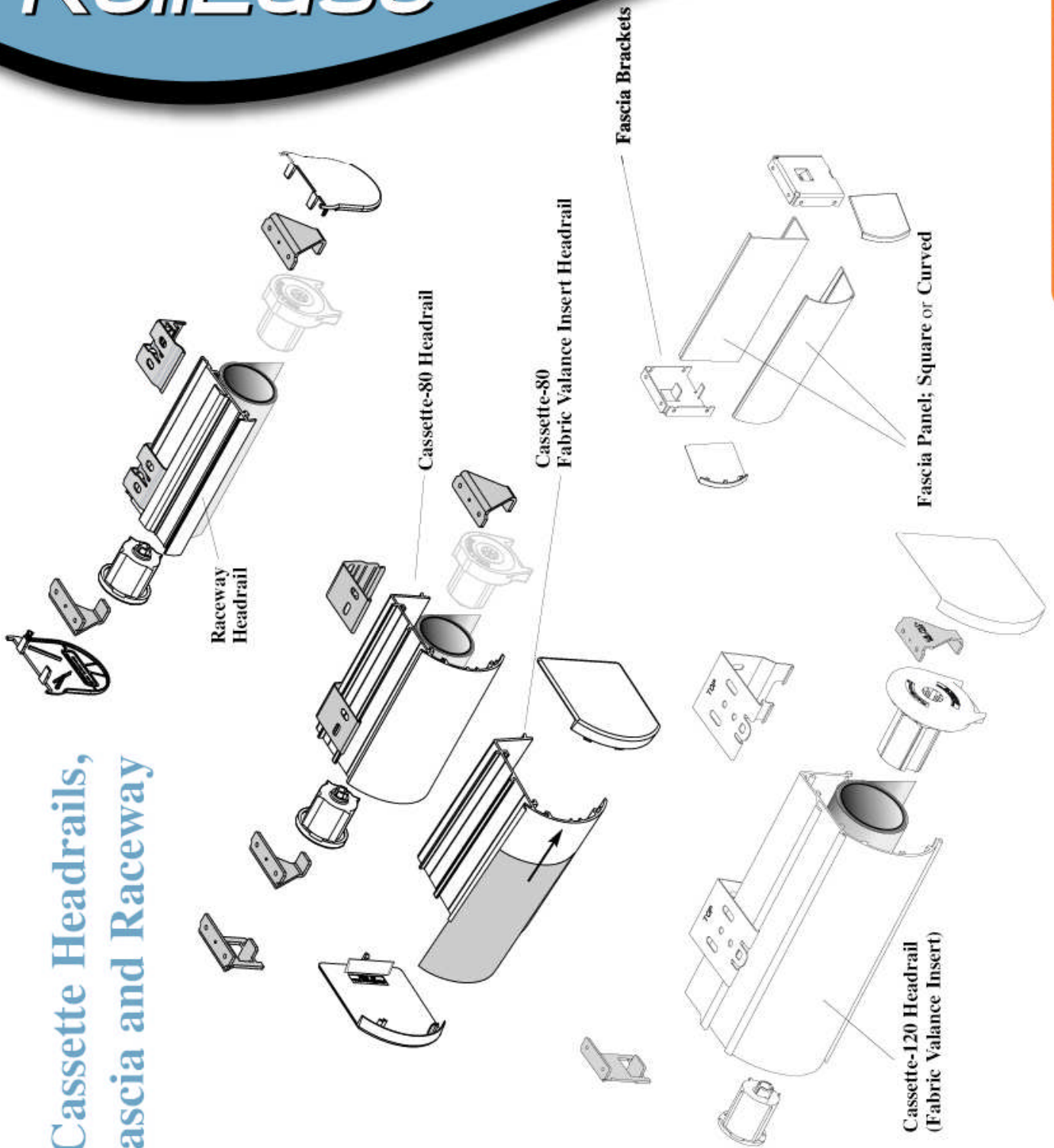

3-Inch (76mm) Pocket System

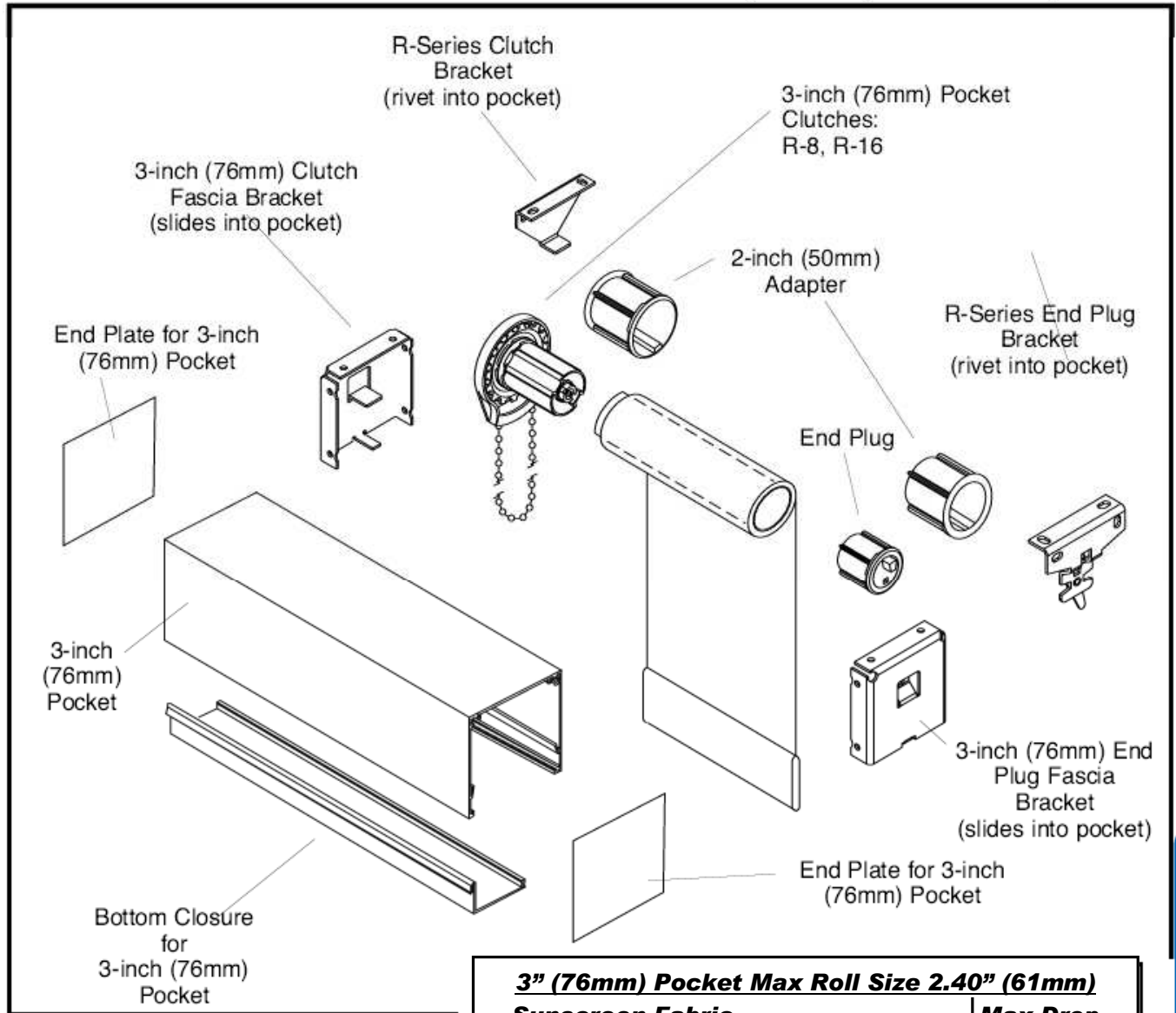

| 3" (76mm) Pocket Max Roll Size 2.40" (61mm) | |
|--|-------------------|
| Sunscreen Fabric | |
| Nordic Screen 5% on 1.25" (32mm) tube | 168"(4,3m) |
| Nordic Screen 5% on 1.50" (32mm) tube | 148"(3,7m) |
| Nordic Screen 5% on 1.25" (32mm) tube | 84"(2,1m) |
| Nordic Screen 5% on 1.50" (32mm) tube | 72"(1,8m) |

Note: The roll size calculation does not take into consideration tube deflection.

TECHNICAL

4-inch (102mm) Pocket & Blackout System

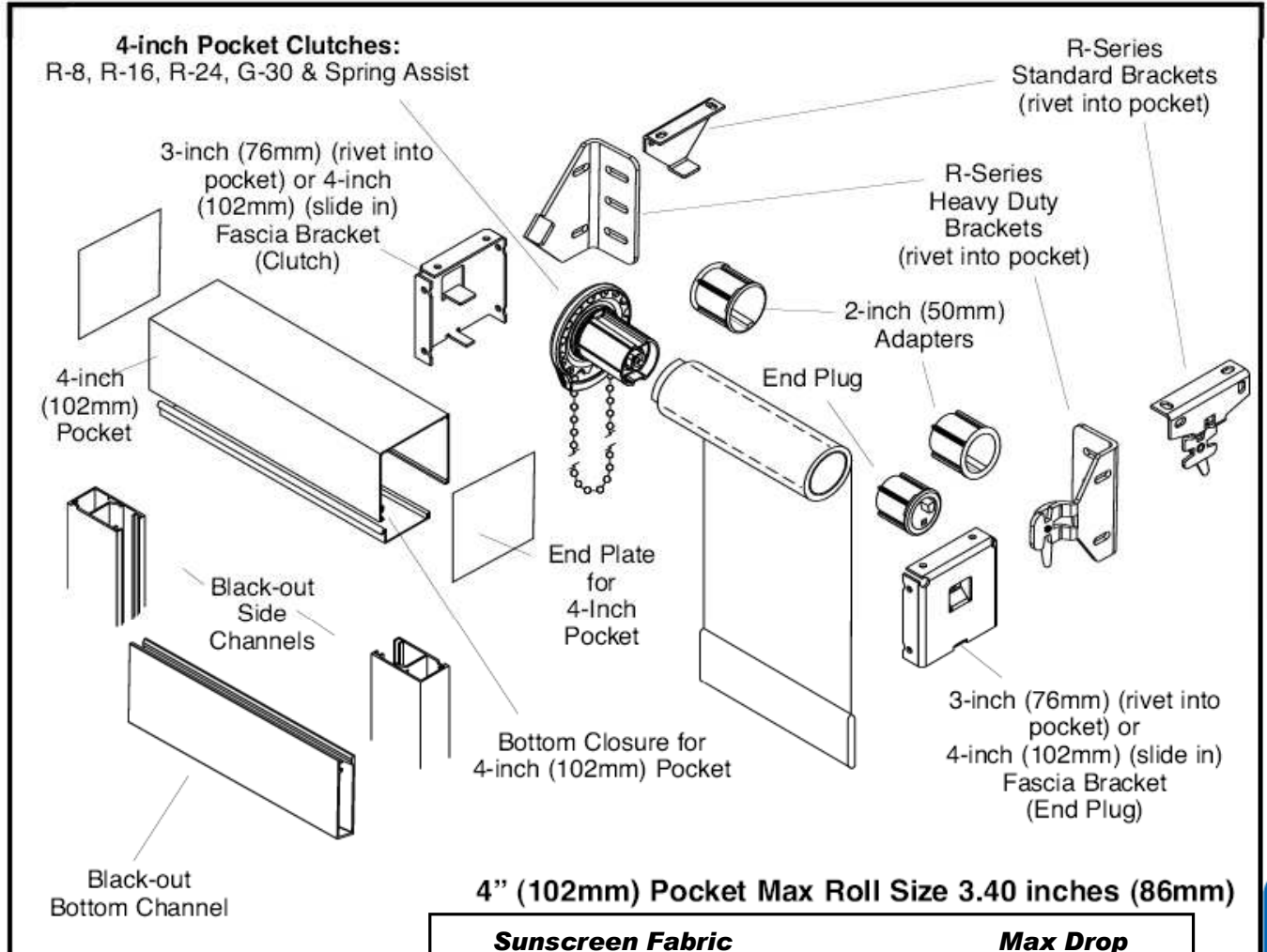

4" (102mm) Pocket Max Roll Size 3.40 inches (86mm)

| Sunscreen Fabric | Max Drop |
|--|-------------------|
| Nordic Screen 5% on 1.25" (32mm) tube | 168"(4,3m) |
| Nordic Screen 5% on 1.50" (32mm) tube | 148"(3,7m) |
| Nordic Screen 5% on 1.25" (32mm) tube | 84"(2,1m) |
| Nordic Screen 5% on 1.50" (32mm) tube | 72"(1,8m) |

Note: The roll size calculation does not take into consideration tube deflection.

TECHNICAL

6-inch Pocket & Blackout System

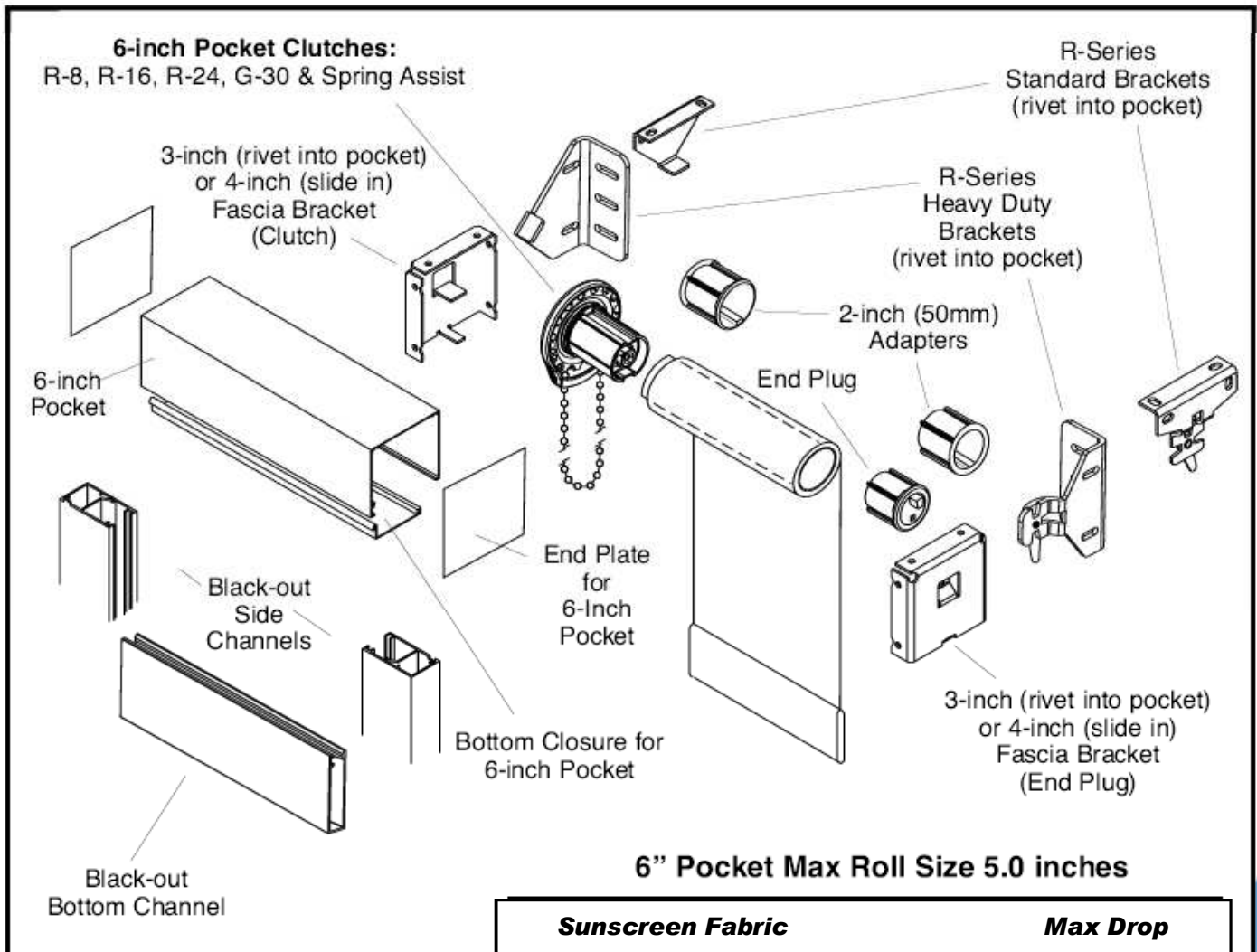

| Sunscreen Fabric | Max Drop |
|--|------------------|
| Nordic Screen 5% on 1.25" (32mm) tube | Over 240" |
| Nordic Screen 5% on 1.50" (32mm) tube | Over 240" |
| Nordic Screen 5% on 1.25" (32mm) tube | Over 240" |
| Nordic Screen 5% on 1.50" (32mm) tube | Over 240" |

Note: The roll size calculation does not take into consideration tube deflection or weight versus width issues.

TECHNICAL

R-Series Installation

1. MOUNT THE BRACKETS.

If the clutch is on the right end of the shade, attach the brackets to the window frame, window molding, wall or ceiling, as shown below. If the clutch is on the left end of the shade, reverse the bracket positions, left for right.

TO THE INSIDE OF
THE WINDOW FRAME

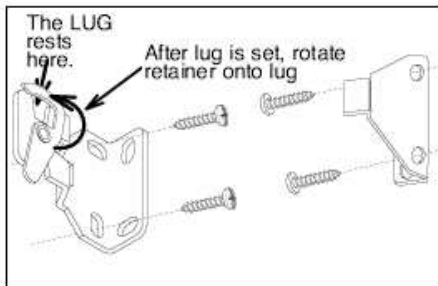

TO THE WALL OR TO THE
FRONT OF THE WINDOW MOLDING

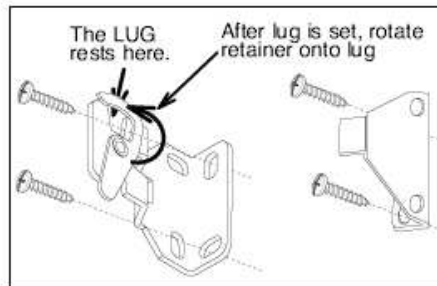

TO THE CEILING OR TO THE
TOP OF THE WINDOW FRAME

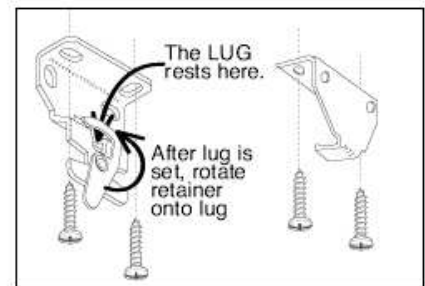

2. INSTALL THE SHADE.

- Push the clutch straight onto the blade of its bracket. The bottom of the clutch should always point straight down.
- Lower the lug of the end plug onto the "V" of its bracket. The roller should fit in the brackets securely, with just a little play. Rotate the riveted retainer portion to lock the lug in position.

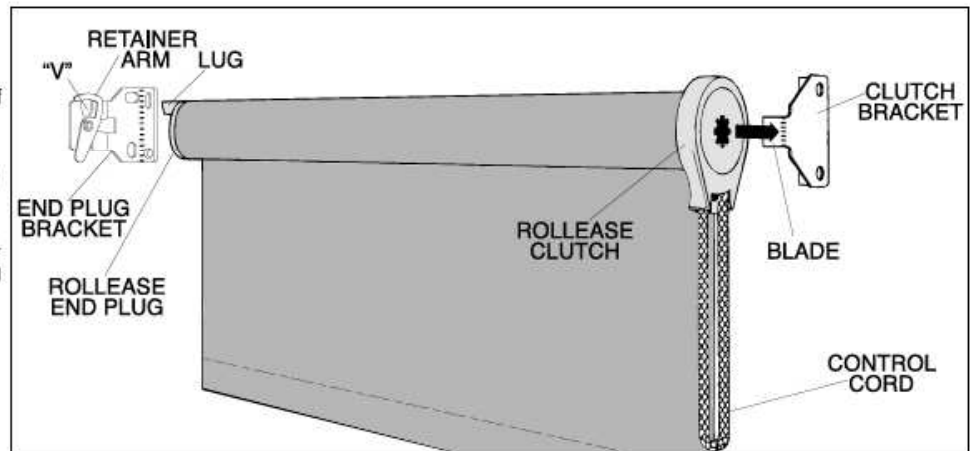

3. INSTALL THE TENSION DEVICE

See page R30 for details



4. USE THE CONTROL CORD TO OPERATE THE SHADE.

Pulling gently on the cord in one direction raises the shade; pulling it in the other direction lowers it.

On shades where the fabric rolls against the window, the front cord does the raising. On shades where the fabric rolls toward the room, the rear cord does the raising.

5. ATTACH STOPS TO A CONTROL CORD THAT'S MADE OF BEAD CHAIN.

On metal bead chain, attach a metal stop ball that is at least 5/16" (8mm) in diameter, so that it touches the mouth of the clutch when the shade is in the all-rolled-up position.

For metal or plastic bead chain, lower the shade to sill or floor height, and attach the appropriate metal stop or plastic connector next to the clutch, this prevents the shade from being lowered beyond that point.

R-Series Fascia Fabrication - Installation

7. **CUT FASCIA PANEL TO DIMENSION "A"** as calculated in step 1, over.

8. **CUT AN OPENING IN THE BOTTOM OF THE CLUTCH END OF THE FASCIA PANEL. DEBURR THE CUT EDGES.** The clutch bottom and control cord will fit through this opening. The openings for the R8 and R16 clutches are shown for left-hand control. The opening for the R24 clutch is shown for right-hand control.

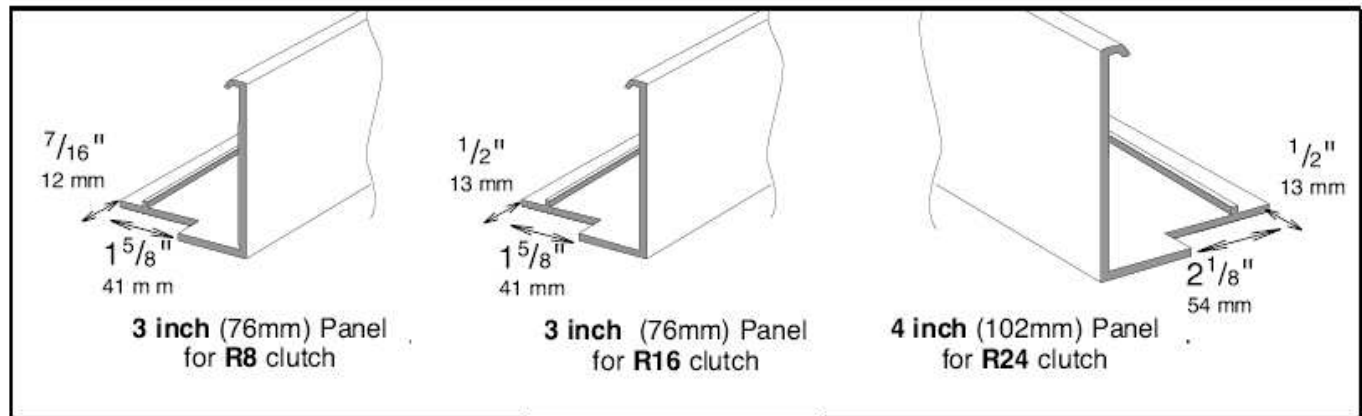

INSTALLATION

1. **MOUNT THE BRACKETS.** The open end of each bracket faces downward, as shown in the drawing below. **NOTE:** If you have an inside mount and must use inside mount holes, you will have to drill your own holes in the side of the bracket. Use at least two screws per bracket, and make sure that the screw heads clear the clutch.

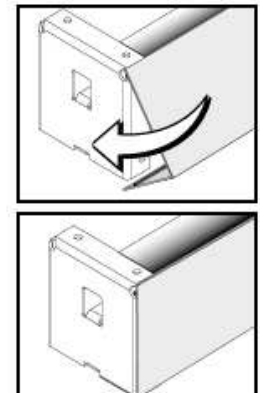
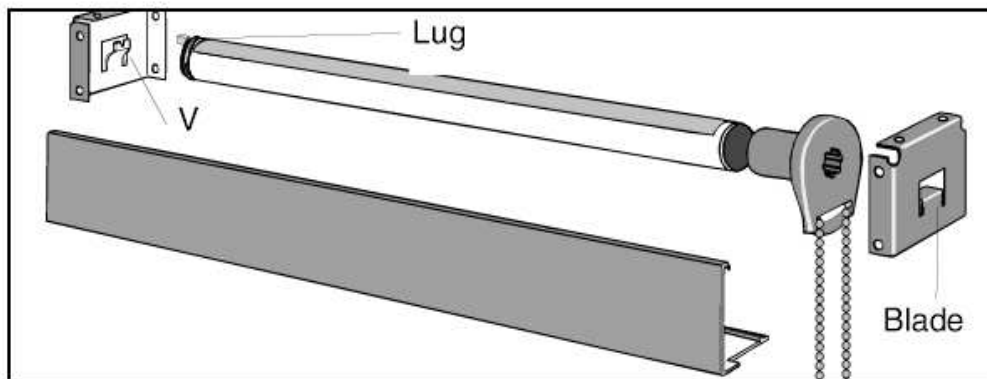

2. **INSTALL THE SHADE.** Push the clutch straight onto the blade of its bracket. The bottom of the clutch should always point straight down, as shown above. Lower the lug of the end plug onto the V of its bracket. The roller should fit in the brackets securely, with just a little play.

ATTACH FASCIA PANEL Attach the fascia by first hooking the top lip of the fascia panel onto the bracket as shown. Swing the bottom the fascia panel towards the bracket and gently press at the bottom to the panel until the lip on the fascia engages and snaps locked to the bracket.

3. **ATTACH STOPS TO METAL OR PLASTIC BEAD CHAIN.** For plastic bead chain: use connector for top stop and attach another connector for lower stop. For metal bead chain: attach a metal stop ball at least $\frac{5}{16}$ inch (8 mm) in diameter so that it touches the clutch when the shade is rolled all the way up. For both kinds of bead chain, lower the shade to sill or floor height, and snap the appropriate metal stop or plastic connector on the opposite side from the stop, so that the shade cannot be lowered beyond that point.
4. **INSTALL THE TENSION DEVICE:** See page R30 for details
5. **USE THE CONTROL CORD OR BEAD CHAIN TO OPERATE THE SHADE.** Pulling gently on one side of the control cord or bead chain raises the shade; pulling down on the other side lowers it.

Cassette Installation

1. **Mount the brackets** to the wall or window frame, with the outside brackets no further than 2 inches (50mm) from the ends of the headrail. On wide shades, space the additional bracket(s) at equal intervals.

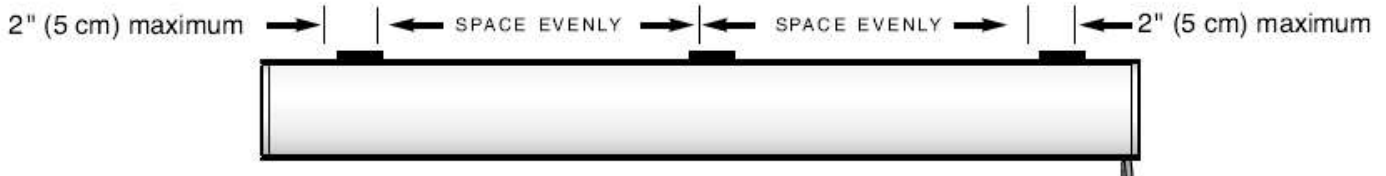

Cassette 80

For **wall or outside mounts**, use the rear bracket holes.

Make sure the release tab is always mounted on the bottom.

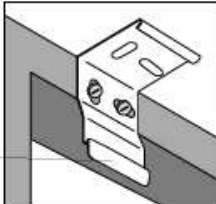

For **inside or ceiling mounts**, use the top bracket holes.

Make sure the release tab is always mounted on the bottom.

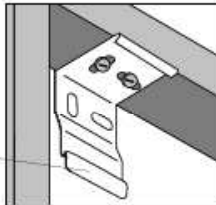

Mount the headrail. Position the headrail with the front panel (A) resting on the top lip of all brackets. Push the bottom front of the headrail firmly backwards and toward the window until the lip on the rear of the headrail engages the bracket and snaps into place, (B) as shown.

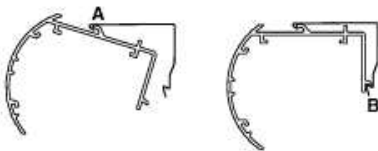

Raceway

For **wall or outside mounts**, use the rear bracket holes.

Make sure the release tab is always mounted on the top.

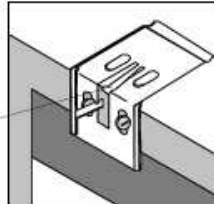

For **inside or ceiling mounts**, use the top bracket holes.

Make sure the release tab is always mounted on the top.

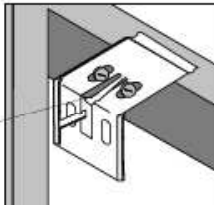

Mount the headrail. Position the headrail so that the furthest lip of the bracket slides underneath the the groove on the headrail at (A). Push the front of the headrail firmly backwards and toward the window until the lip on the rear of the headrail engages the bracket and snaps into place, (B) as shown.



Cassette 120

For **wall or outside mounts**, use the rear bracket holes.

Make sure the release tab is always mounted on the top.

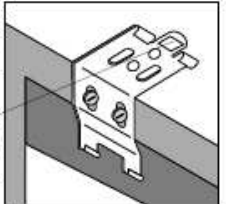

For **inside or ceiling mounts**, use the top bracket holes.

Make sure the release tab is always mounted on the top.

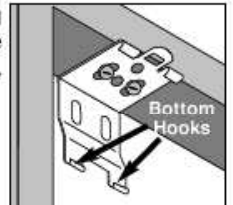

Mount the headrail. Position the headrail with the back panel (A) resting on both bottom hooks of all brackets. Push the front of the headrail firmly upwards and toward the window until the groove at the top of the headrail snaps into place, (B) as shown.

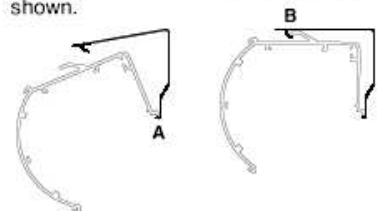

2. **Install the Tension Device.** See page R30 for details

3. **Operate the shade** by pulling down on one side of the cord — one side of the cord raises the shade, the other side lowers the shade. Do not lift the bottom rail with your hands. Also, be careful not to place objects on the window sill that will interfere with operating the shade or cause it to hang unevenly

4. **To remove a shade; Cassette 80:** from the bottom rear of the headrail insert a flathead screwdriver in between the headrail and release tab. Gently twist the screwdriver and pry open the bracket to release the headrail. **Raceway:** Insert the screwdriver behind the headrail and engage the release tab.. press it upward to release the headrail. **Cassette 120:** from the top front of the headrail insert a flathead screwdriver in between the headrail and release tab. Gently twist the screwdriver and pry open the bracket to release the headrail. As you release the brackets, support the headrail to keep it from falling.

RollEase®

Skyline Installation

Fabricating RollEase Skyline™ Double (Vertical or Horizontal Mount) Brackets

1. Inside mount deductions for the Double Bracket are the same as the regular brackets (see chart on opposite side). **Vertical Brackets:** The upper shade must be a reverse roll shade (rolls off on room side) and the lower shade must be a standard roll shade (rolls off on window side). **Horizontal Brackets:** Shades can be mounted in any combination (front roll/reverse roll) Double Shades may also share a center bracket as shown in the illustration (see shared bracket deductions chart on page SL-20)

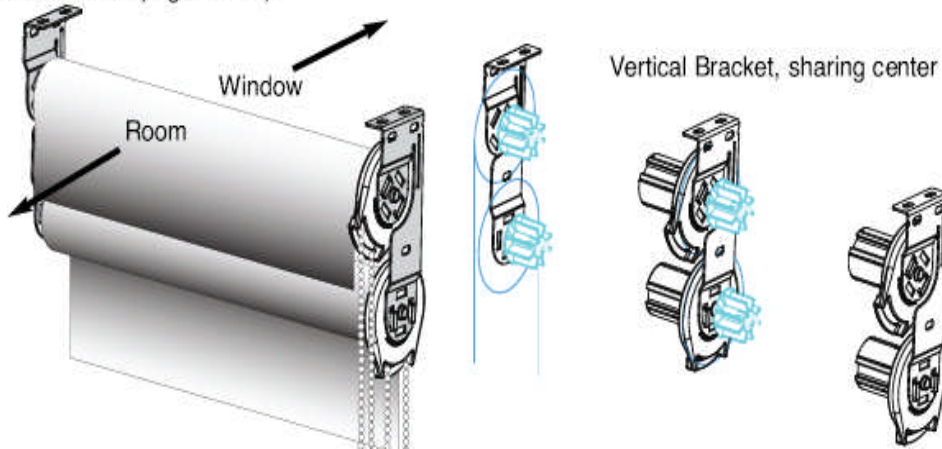
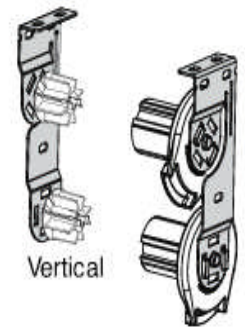
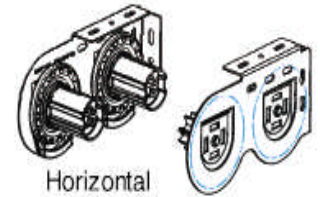

Bracket Dimensions

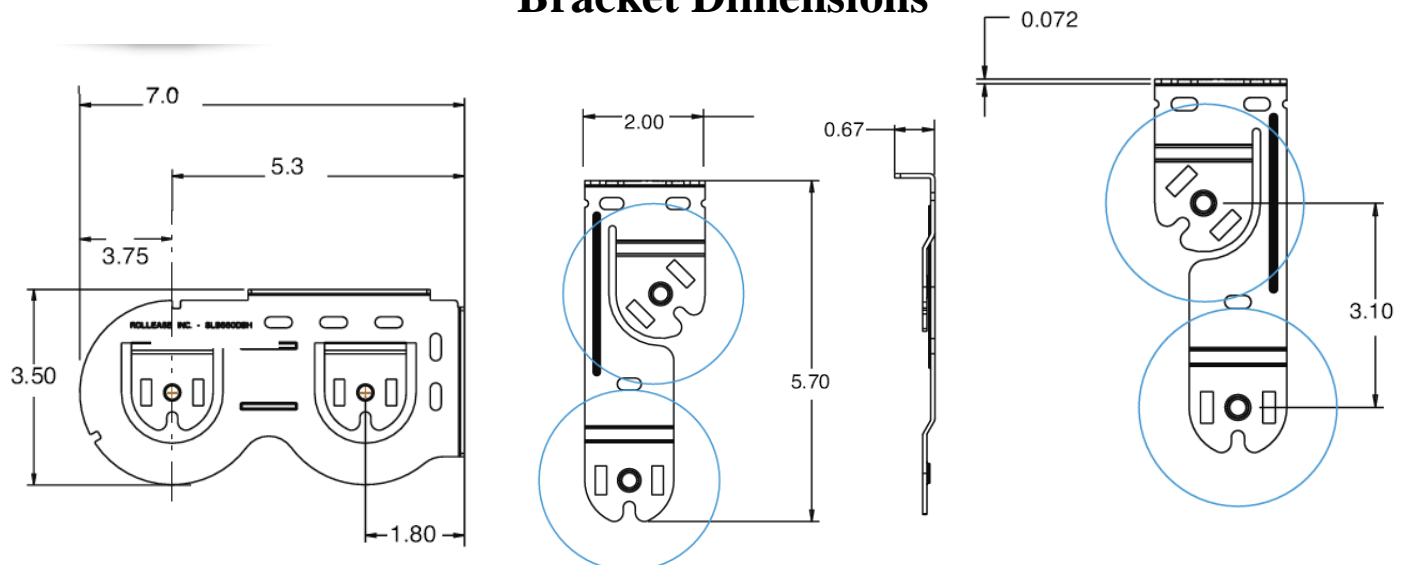

Vienna Cassette

Headrail Installation and Specifications

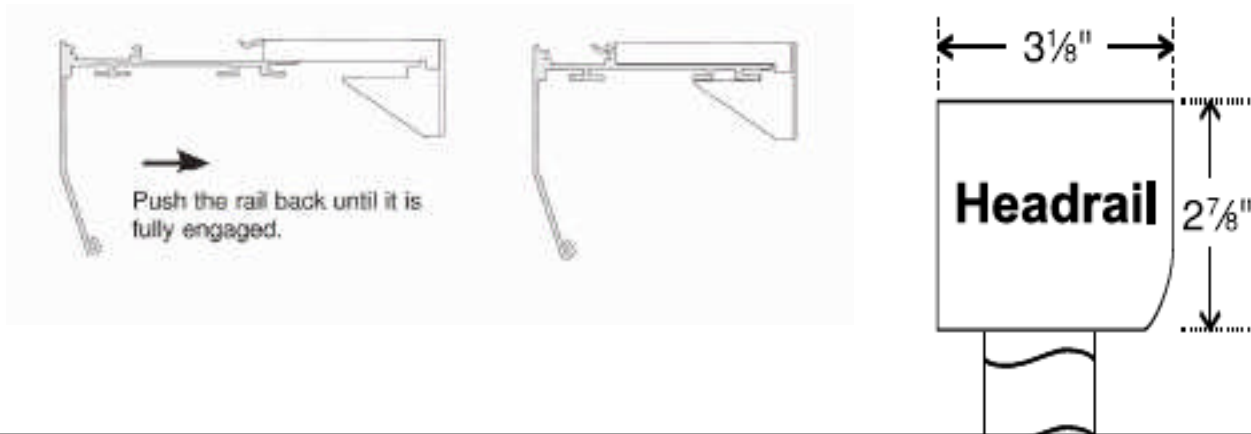

Common Terms and Definitions

Glaze: To glaze a window is to furnish it with glass or other material. The glass or other material may then be referred to as the glazing material. When drapes, blinds, shades and other heat control devices are used in combination with glass, the combination is referred to as a glazing system.

Openness Factor (O-F): Refers to the ratio of open or interstice area to the total flat surface area of a drapery fabric or perforated material. This quantity relates well to the amount of solar heat admitted through a fabric or perforated material and to the extent to which discomfort results to individuals near glazing system.

Shading Coefficient (SC): Defines the sun control capability of the glazing system. It is expressed as the ratio of solar heat gain through any given glazing system to the solar heat gain that would occur under the same condition of the window under consideration were glazed clear, unshaded, double strength window glass, designated DSA. It is utilized in calculation of the solar heat gain and total heat gain of the glazing material or glazing system.

Solar Absorptance (As): The ratio of the amount of total solar energy which is absorbed by a glazing system to the amount of total solar energy falling on the glazing system (the portion of the solar energy which is reflected or transmitted.)

Solar Reflection (Rs): The ratio of the amount of total solar energy, which is reflected outward by a glazing system to the amount of total solar energy falling on the glazing system.

Solar Transmittance (Ts): The ratio of the amount of total solar energy allowed passing through a glazing system to the amount of total solar energy falling on the glazing system.

UV Transmittance (Tuv): The transmittance of the glazing/product for the UV range of the solar spectrum. This value is used as a rating to determine the product/glazing effectiveness in guarding against UV degradation. This value is directly related to the openness factor of the solar protection material used.

Visible Transmittance (Tv): The ratio of the amount of total visible solar energy which is allowed to pass through a glazing system. It is related to the amount of glare a person receives through a glazing system.

SOMFY L T RTS Motors at a Glance

1. The Right Motor Solution for Every Job, Due to a Wide Range of Models

- Expanded product line in terms of lifting capacity and operating speed
- First manual override motor with built-in radio technology "CMO RTS".

2. Quick and Easy Installation

- Reduced number of mechanical accessories
- Can be installed in 6 different positions
- Minimum side space requirement (23mm)
- Motor and drive are attached with a simple click connection (no screws required)

3. Convenience for the End User

- Features quiet operation due to the use of advanced product components

5. Easy Limit Switch Setting

- Limits are set via remote radio transmitter

6. All SOMFY Motors are UL and C SA Recognized

- SOMFY UL Recognized motors can be found in the following file numbers: E60495, E60888, E63714.



4. Simple Electrical Connection

- New UL approved 5-15P Nema plug-in motor cable simplifies electrical connections
- Plugs into a standard electrical receptacle and eliminates the need for an electrician
- Motor cable length can be customized to meet your installation requirements



Innovative: Drive is attached with a simple click on connection.

Altus RTS

With RTS (Radio Technology Somfy™), installation and user operation has been simplified and the overall performance of motorized window coverings, projection screens, awnings and rolling shutters have been enhanced. Designed with all of the great features of SOMFY's popular LT motors, the Altus RTS motor shares one important distinction... A radio remote control receiver is built into the motor providing the user with remote control capabilities without added wiring.

With the Altus RTS motor the end user can have wireless control over any motorized window covering via a radio remote control transmitter or a Decora RTS wireless wall switch within a range of up to 90 feet in open space and up to 65 feet through two concrete walls. The RTS motor can be parallel wired which eliminates the need to connect switches and to access a control device. It also eliminates long wire runs which are often time consuming and expensive.



**DECORA RTS 4
WIRELESS
WALL SWITCH**

The Altus RTS motor features a user programmable intermediate stop position and operates on a narrow bandwidth that is less susceptible to interference (433.42 MHz). The RTS system also features 1.6 million rolling codes to provide for maximum security.

The Telis RTS transmitters and Decora RTS wireless wall switches enable a user to program individual, group and master control to optimize operational convenience and to customize the system to meet virtually any design requirement.

The Altus RTS motor is compatible with the RTS sun and wind sensors to provide a measure of protection when used with retractable awnings.

